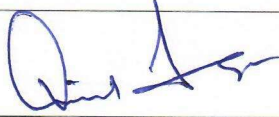



Corporate Standard Rules & Procedure Sub-Committee	Date	06-07-2014
	Standard Document No.	HZL/SRPSC/01
<b>Working at Height Standard</b>	Revision No.	02 (22.02.2023)
	Page No.	Page 1 of 33

**HINDUSTAN ZINC**  
Zinc & Silver of India

## HZL Standards

## Working at Height

	Issued by	Approved by
Name	Chairman, Corporate SRP Sub Committee	Chairman, Corporate Safety Council
Sign.		
Date	22-02-2023	

Corporate Standard Rules & Procedure Sub-Committee	Date	06-07-2014
	Standard Document No.	HZL/SRPSC/01
<b>Working at Height Standard</b>	Revision No.	02 (22.02.2023)
	Page No.	Page 2 of 33

**Document Control Details**

Revision	Date	Reason For Issue	Compiled by	Approved by
0		Corporate Standard		Apex
Next Date	Review			

**User Notes:** - The Corporate Safety Council (CSC) is the custodian of this document and is responsible for the Administration and Authorization of this Standard. CSC is responsible for confirming the accuracy and integrity of content and proposed changes to the Standard.

Controlled copy of the current version of this document is held at CSC and also available on its portal. Any printed / electronic copy of this document is uncontrolled. It is recommended that users verify that the version being used by them is the current version by referring to the controlled version.

Corporate Standard Rules & Procedure Sub-Committee	Date	06-07-2014
	Standard Document No.	HZL/SRPSC/01
<b>Working at Height Standard</b>	Revision No.	02 (22.02.2023)
	Page No.	Page 3 of 33


**Acknowledgement** The management acknowledges the contributions of the following individuals for being a part of the Zone / location workgroup and for their assistance in preparing this standard on Working at Height.

<b>Zone / Location</b>	<b>Members</b>
Corporate champion	Mr. Manoj Soni
Zone-1: RDC	Mr. Vijay Goyal
	Mr. R.P.Pal
	Mr. Abhishek Pathak
	Mr. MD Singh
	Mr. R Balaji
	Mr Naveen R P
	Mr. Durgadas Rathore
Zone-2	Mr. Vivek Yadav
	Mr. Jackson Ignatius
	Mr. V. K. Jain
	Mr. MK Arha
Zone-3	Mr. J Sarkar
	Mr. Arjun Lal Bairwa
Zone-4	Mr. Lokesh Paliwal
	Mr. CSV Prasad
Zone-5	Mr. Deepak Wilson

Corporate Standard Rules & Procedure Sub-Committee	Date	06-07-2014
	Standard Document No.	HZL/SRPSC/01
<b>Working at Height Standard</b>	Revision No.	02 (22.02.2023)
	Page No.	Page 4 of 33

**DOCUMENT ISSUE**

The Working at Height Standard is issued by the Corporate Safety Council on behalf of Hindustan Zinc Limited management and form a part of the of HZL Integrated Management System.

Name: ..... *Vinod Jangir*  
Signed: .....   
Date: ..... *22-02-2023*

This document contains proprietary and confidential information of Hindustan Zinc Limited and is intended solely for the internal use of authorized personnel. This should be treated as BUSINESS CONFIDENTIAL and its external use or disclosure, unless specifically authorised, is strictly prohibited.

Corporate Standard Rules & Procedure Sub-Committee	Date	06-07-2014
	Standard Document No.	HZL/SRPSC/01
<b>Working at Height Standard</b>	Revision No.	02 (22.02.2023)
	Page No.	Page 5 of 33

### Abbreviations

- HZL – Hindustan Zinc Limited
- HSE – Health, Safety and Environment
- IMS – Integrated Management System
- CSC – Corporate Safety Council
- UIC – Unit Implementation Committee
- ZASC – Zone Apex Safety Committee
- SRPSC – Standards, Rules & Procedure Subcommittee
- PPE - Personal Protective Equipment
- OHS - Occupational Health & Safety
- HR - Human Resources
- FAI - First Aid Injury
- MTI - Medical Treatment Injury
- LTI - Lost Time Injury
- DINS - Distribution Incidents
- SPI - Serious Process Incident
- OTJ - Off the Job

Corporate Standard Rules & Procedure Sub-Committee	Date	06-07-2014
	Standard Document No.	HZL/SRPSC/01
<b>Working at Height Standard</b>	Revision No.	02 (22.02.2023)
	Page No.	Page 6 of 33

## Table of Contents

S. No.	Particulars	Page No.
	Document control details	2
	Acknowledgement	3
	Document issue	4
	Abbreviations	5
	Table of contents	6
1	Introduction	7
1.1	Intent and purpose	7
2	Scope and field of application	7
2.1	Scope	7
3	References	7
4	Management responsibilities	8
5	Definitions	8
6	Standards/guidelines	10
6.1	Principles of working at height	10
6.1.1	Identification of hazards and risk assessment	11
6.1.2	Planning and preparation	11
6.1.3	Working at height protection equipment	12
6.1.4	Execution	20
6.1.5	Inspection requirements:	21
6.1.6	Training	22
6.1.7	Special requirements	22
7.0	RACI chart	29
8.0	Key performance indicators:	30
9.0	Management systems	30
10.0	Fall arrest system checklist	31

Corporate Standard Rules & Procedure Sub-Committee	Date	06-07-2014
	Standard Document No.	HZL/SRPSC/01
<b>Working at Height Standard</b>	Revision No.	02 (22.02.2023)
	Page No.	Page 7 of 33

## 1. Introduction

This standard describes the principles used to protect employees from the hazards of working at height. It provides helpful information to facilities as they implement procedures to control the hazards associated with working at height in keeping with the HZL management commitment.

### 1.1. Intent and Purpose

This standard has been developed by cross functional team from all zones of HZL. The requirements which have been identified here are equally applicable across all Zones/ sites of HZL. This will also help in bringing about a consistency in the process used across all locations.

The Standard will help to provide a new impetus towards achieving the best in class safety standards. This standard is formulated based on best practices.

## 2. Scope and field of application

### 2.1. Scope

This standard describes the principles used to protect employees from the hazards of working at height.

Working at height standard shall be applicable whenever there is an elevation difference of 1.8 M or more, and where there is a fall potential due to absence of any physical protection such as a permanent platform with complete guardrails. Work at height standard will also be applicable at less than 1.8 M elevation difference where the fall hazard exists. Hazard due to dynamic movement at height is also to be covered in risk assessment.

Businesses/Locations should be aware that local regulations might impose conditions not reflected in this standard. Additional information on regulations comes from a number of sources, including Statutory/Regulatory Documents.

### Field of application

This Standard and procedure is applicable to all locations/sites/ Projects of Hindustan Zinc Limited.

## 3.0 References

### Corporate Policy

HZL HSE Policy

HZL Safety Principles

### Corporate Standards

GN 21: Work at Height

Applicable Corporate Safety Standard

Permit to Work System

Confined Space Entry

Scaffold Safety

Safety Harness and Fall Protection Systems

Corporate Standard Rules & Procedure Sub-Committee	Date	06-07-2014
	Standard Document No.	HZL/SRPSC/01
<b>Working at Height Standard</b>	Revision No.	02 (22.02.2023)
	Page No.	Page 8 of 33

Other references

IS Standards

Local/National Regulations on Working at Height

#### 4. Management Responsibilities

Line management has the responsibility to implement this standard.

#### 5. Definitions

**Permit Co-permittee** —a person at the perimeter of the work area who is assigned the role of monitoring and communicating with the authorized workers, controlling access to the area, maintaining designated conditions as specified on the permit, and initiating the rescue plan.

**Certification**—a verification process, which documents that a person has the necessary training, skill, competency, experience and the ability to perform designated roles and tasks.

**Working at height** — Elevated working positions where the risk of a fall from height exists and where there is no physical protection such as standard platform. Types of work covered include working from all types of ladders, scaffolds, chimney, mechanical lifts, mobile cranes, Heavy Earth Moving Equipment, sloped roofs including fragile roofs, side sheeting, when working within 1.8 meter of the edge of a flat roof, erecting steel or installing/replacing roofing and in pipe racks. This may exclude normal work on low stepladders, loading platforms with fixed handrails, or similar locations.

**Work permit**—the written or printed document that is issued to administratively control and authorize working at height tasks/ activities.

**Permit Custodian** —a person who is authorized to sign work permit on the behalf of Factory Manager/ Mines Manager/ Project Head and is authorized by unit head/ operation head/ engineering head/ project head or in-charge to verify that all conditions for working at height have been met, to define ongoing precautions to maintain safe working conditions during the work, to authorize the work to occur, and to cancel the permit.

**Permit Initiator** – The person who applies for a Permit and completes the work description in the work permit for approval by the Permit Authorizer. He is responsible for ensuring that a Permit Holder is appointed at all times when the work is under way.

**Permit Issuer: Authorized person who ensures clause B (Extra safety requirement from custodian), clause-C (Ensures from authorized isolator that all requested isolation from initiator is done and checked in field) and clause-D of work permit and give clearance to start job.**

**Factory Manager/ Mines Manager/ Project Head:** A person who is legally notified and authorized by occupier to discharge his duties.

**Full Body Harness** - A full body harness is the body wear with 6 points contact, heavy duty, which can be attached to the anchor point with double lanyard/fall arrestor.

**Lanyard** - A flexible line to secure the wearer (chest, waist and thighs) of a safety harness to a lifeline or fixed anchorage point. Maximum length of lanyard is 1.8 M. **Only polypropylene lanyard is approved**



Corporate Standard Rules & Procedure Sub-Committee	Date	06-07-2014
	Standard Document No.	HZL/SRPSC/01
<b>Working at Height Standard</b>	Revision No.	02 (22.02.2023)
	Page No.	Page 9 of 33

**Double Lanyard** - A system utilizing two lanyards connected in a "Y" configuration, which allows one lanyard to be attached to an anchor point while the second lanyard is being moved to a new anchor point, thus providing protection from fall at all times.

**Shock Absorber** – A device used in combination with lanyards that is designed to reduce the force when fall is occurred.

**Double Action Locking Snap Hook** - A device for securing lanyards that requires two separate locking pins be depressed before the snap will open.

**Anchor Point** - A secure point of attachment for lifelines, lanyards, or retractable lifelines. Steel structures may be used as an anchor point with proper risk assessment. Sprinkler piping, instrument tubing, hydraulic pipes, hand rails shall not be used as an anchor point. **All permanent anchor points must be tested for load of 2.2 MT every year .**

**Lifeline** - A flexible cable, either horizontal or vertical, which is anchored at both ends and to which other personal fall protection devices can be attached. Lifeline for anchorage of lanyard should be minimum 19 mm dia Manila rope or 12 mm dia steel rope for taking impact load of 23 KN(As per OSHA) (one person only). It should be free from abrasion, distortion and damage. Other modified lifelines for 2 or more person can be used as per OSHA standard and manufacturers recommendation . 8mm SS wire rope is accepted as a standard wire rope for fixed life line installations which also acts as a shock absorbing element in event of fall .

**Retractable Lifeline** - A retracting lifeline which allows free travel without slack rope, but locks instantly when a fall begins. These devices must limit the force of deceleration to no more than 800 pounds (~365kg) and are only recommended for vertical descent.

**Rope Grab** - These are automatic lifeline devices which act by inertia to grab the vertical lifeline should a fall occur. Rope Grab shall be 19mm (¾”) synthetic rope or 12 mm (½”) wire cable.

**Continuous Anchorage** - The requirement that a person be tied off at all times when working in an elevated areas where the potential for falls exists. This is most commonly accomplished by using double lanyards, a horizontal, vertical lifeline, or a retractable lifeline.

**Working From A Ladder** - Any work from a ladder requiring employee’s feet to be above 1.8 meter and use of both hands.

**Qualified Installer** - Any professional, experienced Fall Protection Systems person who has been specifically trained in the installation of lifelines and fall protection systems.

**Qualified Inspector** - Any person who has been specifically trained to inspect and evaluate the condition of harnesses, lanyards, etc. (Tested and certified by competent authority in every 6 months)

### **Risk Assessment**

A process used to assess the risk associated with any activity by identifying the hazards and evaluating the control measures, before starting the job. Risk assessment to be done as per GN 07 standard of Vedanta. For example: Hazard Identification Risk Analysis (HIRA), Job Safety Analysis (JSA) etc.

### **Safety Net**

A device used as a fall-protection device for people working at height. Safety nets alone shall not be the

Corporate Standard Rules & Procedure Sub-Committee	Date	06-07-2014
	Standard Document No.	HZL/SRPSC/01
<b>Working at Height Standard</b>	Revision No.	02 (22.02.2023)
	Page No.	Page 10 of 33

means of fall protection and shall be used only as a secondary fall-protection.

Safety nets are also used to protect people working below from falling personnel and materials. All nets must meet IS: 11057- 1984 standard.

## 6. Standards/Guidelines

### 6.1. Principles of Working at Height

When working on elevated surfaces or height more than 1.8 meter.

Wherever there is a possibility of a fall that could result in injury, good judgment is necessary to ensure that adequate and proper protection is worn when required. The following are some typical examples, illustrating where a safety full body harness should be used.

- Elevated working positions where the risk of a fall exists and where there is no physical protection such as handrails. This may exclude normal work on low stepladders, loading platforms with fixed handrails, or similar locations.
- Working near unprotected roof edges or on sloping roofs.
- Working on open steel structures, form work, piping, or equipment.
- Working from straight ladders when both hands are needed for work.
- Working on incomplete scaffolds, suspended stage or other type of suspended scaffolding.

The following hierarchy of control should be applied (in the order of preference) when there is a need to work at height,

- Eliminate the 'Work at Height' hazards.
- Reduce the risks to an acceptable level (through use of well designed and engineered fixed platforms, ladders etc. or alternatively, through use of a well designed scaffold, as necessary)
- Use other required personal protective equipment (PPE) like a full body safety harness.

#### Requirements for working at height

- Identification of hazards and risk assessment
- Planning and preparation
- Protective equipment
- Execution
- Training and certification
- Inspections
- Special requirements

##### 6.1.1. Identification of hazards and risk assessment

Corporate Standard Rules & Procedure Sub-Committee	Date	06-07-2014
	Standard Document No.	HZL/SRPSC/01
<b>Working at Height Standard</b>	Revision No.	02 (22.02.2023)
	Page No.	Page 11 of 33

HZL shall carry out inspection of location where the work has to be carried out to identify hazard including specific location constraints and any other specific requirements associated with working at height. The risk assessment (HIRA, JSA etc) report has to be prepared and documented.

HZL shall list down the activities, equipments required for specific job. Based on these inputs, resources shall be allocated and assign responsibilities for safety during work at height. Persons involved in the job should be properly trained and screened for any height phobia.

This is the responsibility of Permit Applicant.

### **6.1.2. Planning and Preparation**

Based on the Risk Assessment, the applicable sites/ area shall mobilize the fall arrest systems, other equipments and manpower.

**The sites/ area shall ensure that appropriate rescue equipment, along with a trained rescue team and rescue plan is available.**

Personal Fall Arrest System components must be visually inspected before each use.

Proper scaffolds and/or temporary work platforms shall be provided for working at height at elevations 1.8 meters or more where no permanent work platform is available to work safely. The elevated work platforms shall have guardrails (Refer IS 4912 -1978)

**Working from ladders shall be discouraged. Rope ladders shall not be used for working at height. Make shift arrangements viz., drums, barrels; chairs, etc. shall not be used as work platform to work at height.**

Proper area barricading to prevent people walking across and below the working area shall be done before commencing any work at height. If such barricading is not possible, safety net shall be provided and “**Work in Progress**” boards shall be displayed.

Corporate Standard Rules & Procedure Sub-Committee	Date	06-07-2014
	Standard Document No.	HZL/SRPSC/01
<b>Working at Height Standard</b>	Revision No.	02 (22.02.2023)
	Page No.	Page 12 of 33

### **6.1.3 Working at Height Protection Equipment**

#### **Guardrail System:**

Installation of appropriate Guardrail System around the work area is required for fall protection. Guardrail Systems must meet the following minimum requirements:

Top rail (handrail) must be minimum **1050 mm** from the working surface. Mid rails must be located at **525 mm** (midway) between the top rail and the working surface. Toe boards will be provided to prevent persons falling off the working surface. Toe boards must be a minimum of **150 mm** in vertical height.

Screens or panelling from the toe board to the mid or top rail will be required when equipment or material is piled higher than the toe board and is capable of being ejected from the working surface to the level below.

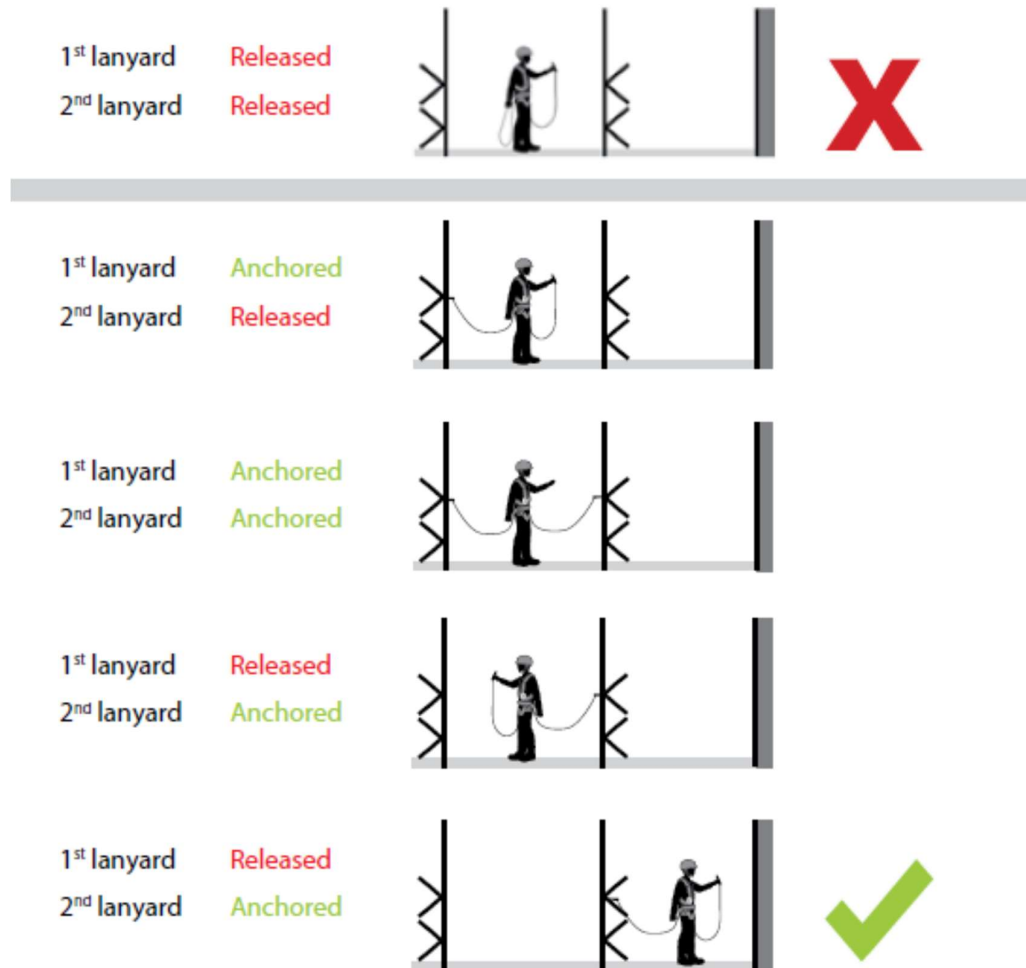
Where gates or openings are required in the guardrail system to facilitate material movement, personal fall arrest or restraint systems must be used.

Every floor opening including opening for temporary maintenance work, into which any person can fall must be guarded by a standard guardrail system or by a metallic grating duly fixed in position. **Whenever any guard rail is removed it is done only through separate PTW and till the time of refixing the guard rail the area needs to be hard barricaded .**

#### **Fall arrest systems**

Fall arrestor system is full body harness with **double lanyard** of 1.8 M length each, out of which, one has to go to the fixed anchorage and another one for movement. So at any given point of time, one of the lanyards is always tied-off providing anchorage 100% of the time (refer figure).

Corporate Standard Rules & Procedure Sub-Committee	Date	06-07-2014
	Standard Document No.	HZL/SRPSC/01
<b>Working at Height Standard</b>	Revision No.	02 (22.02.2023)
	Page No.	Page 13 of 33

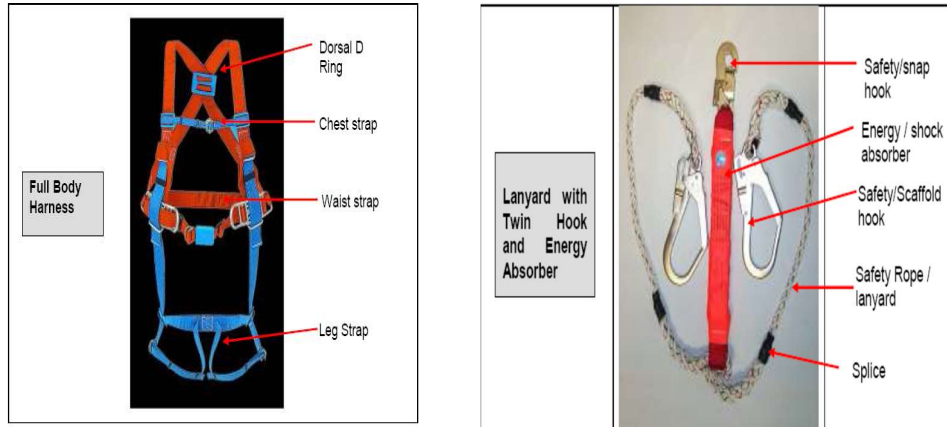


**Figure: 100 percent tie off allows the person fall protection throughout the transfer of anchorage.**

Shock absorbers are preferred to reduce the body injury by absorbing the shock/impact arising in case of sudden fall. Anchor points for fall arresting systems (including lifelines) must be capable of withstanding 2300 kg load per person attached

Safety nets are to be provided for protecting people below from human fall and material fall. Hand tools used while working at height should be secured to avoid free fall in case of accidental slippage.

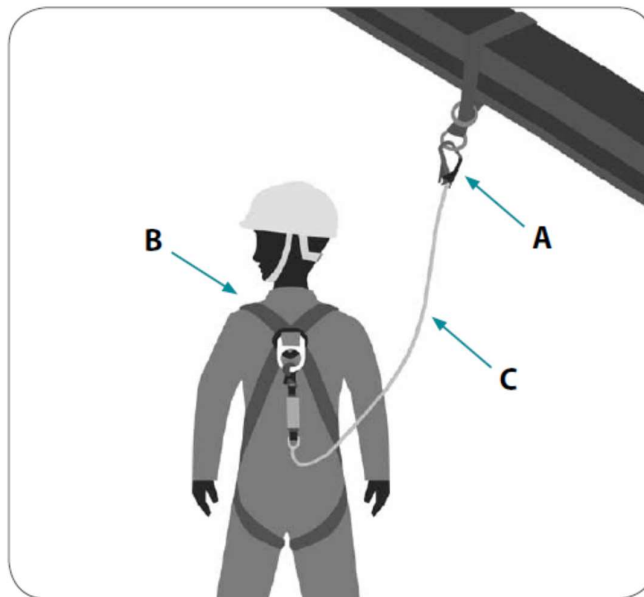
Corporate Standard Rules & Procedure Sub-Committee	Date	06-07-2014
	Standard Document No.	HZL/SRPSC/01
<b>Working at Height Standard</b>	Revision No.	02 (22.02.2023)
	Page No.	Page 14 of 33



**Figure -Full Body Harness with work positioning Device**

In general, a complete personal fall arrest system consists of three vital components:

- Anchorages;
- Body support; and
- Connections.



**Figure: “ABC” of a personal fall arrest system –  
“A”: Anchorage, “B”: Body Support, “C”: Connection.**

Corporate Standard Rules & Procedure Sub-Committee	Date	06-07-2014
	Standard Document No.	HZL/SRPSC/01
<b>Working at Height Standard</b>	Revision No.	02 (22.02.2023)
	Page No.	Page 15 of 33

## **Safety nets**

### ***Safety nets alone shall not be used as a fall protection system***

- All safety net systems shall meet the requirements of Indian Standard (IS: 11057- 1984 )

Safety net mesh openings shall have a **maximum size of 10 cm x 10 cm** and be secured at each crossing to prevent elongation of the opening.

- When in use, the safety net shall have sag at the center not less than 1/5<sup>th</sup> of the length and preferably not more than 1/4<sup>th</sup> of the length of the shorter side. (IS: 11057- 1984 )
- Safety nets shall be installed as close as possible to the working level but in no case more than 6M below the working level.
- The safety nets shall extend out at least 2 M from the side of the open edge.
- Material, equipment and other items that fall into the net are to be promptly removed.
- Safety nets are to be inspected before use and then daily for wear or damage caused by falling materials.
- Safety be inspected by the concerned work supervisor.

Based on risk assessment, the work supervisor decides the use of Safety net.



Photographs (above and below) showing application of Net

### **Barricading/ Warning line systems:**

Based on the hazard, type of barricading shall be provided:

#### **Cautionary Barricades**

The barricades must be minimum 1.8 M away from the edge of the falling hazard (plastic tape & sign board). Barricading tape must be 750 mm above the working surface .

#### **Protective Barricades:**

The barricades installed closer than 1.8 M from the edge of the falling hazard, must be hard barricade which can withstand 100 kg load / thrust and free from sharp edges . Hard barricade shall have horizontal members at 525 mm and minimum 1050 mm respectively from the working floor with adequate vertical supports. This provision can be considered by work supervisor even for more than 1.8 M distance if the situation so demands. **Any opening in the platform and walkway must not be barricaded by cautionary barricade but must be barricaded by permanent barricades .**

Corporate Standard Rules & Procedure Sub-Committee	Date	06-07-2014
	Standard Document No.	HZL/SRPSC/01
<b>Working at Height Standard</b>	Revision No.	02 (22.02.2023)
	Page No.	Page 16 of 33

Barricades constructed with rope, chain or wire shall be provided with warning sign.

### **Provision of ladderways (underground)**

(1) Every shaft or winze ( Raise), including shaft or winze in the course of being sunk, which has an inclination exceeding 25 degrees from the horizontal, shall be provided with a ladderway from the top to the bottom :

Provided that in the case of a shaft or winze in the course of being sunk, the ladderway may be provided within such distance, not exceeding 20 metres, from the bottom as to secure it from danger during blasting operations and a chain or rope ladder shall be provided from this point to the bottom of the shaft or winze

(2) Every working place shall be provided with platforms or other means of keeping a foothold, and where necessary, with ladders from climbing.

(3) Except in respect of the lowest 10 metres or a sinking shaft or winze, no ladder shall be placed at an inclination of more than 75 degrees from the horizontal.

(4) Every ladderway below any place or travelling roadway where persons are stationed or pas, shall be provided with a suitable cover of substantial fence or guard.

(5) Carrying of materials on ladderways. – No person shall carry or be permitted to carry a drill, tool, explosives or any loose material on a ladderway in a shaft or winze having an inclination of more than 45 degrees from the horizontal except so far as may be necessary for carrying out repairs

### **Step Ladders**

- When working from a step ladder, with height less than 1.8 M above the floor, use of fall protection equipment is not required, unless working backward.
- If working on a stepladder with height 1.8 M or higher above the floor, fall protection equipment shall be used.

#### **NOTE**

Fall protection (harness and lanyard) should always be attached to an anchor point before tying off or securing the ladder. It should be detached only after untying the ladder. If no tie off point is available, the ladder shall be continuously held by a second person to provide added stability.

- When working from a ladder where harnesses are not being used, the person on the ladder should avoid stretching to reach objects. A rule of thumb is to not stretch so far that your belt buckle is outside the rails of the ladder.
- Ladder shall not be used for jobs where leaning over ladder is required
- 3- point of contact should be maintained i.e. 2 feet and 1 hand possible

### **Electrical Hazard:**

- Insulated ladders to be used for working on electrical equipment



Corporate Standard Rules & Procedure Sub-Committee	Date	06-07-2014
	Standard Document No.	HZL/SRPSC/01
<b>Working at Height Standard</b>	Revision No.	02 (22.02.2023)
	Page No.	Page 17 of 33

- Portable metal ladders and wooden ladders with metal reinforcements shall be used only during de-energized conditions. Effective supervision shall be provided if there is any proximate hazard of touching live electrical wire or equipment is present.
- No metal ladders or wooden ladders with metal reinforcements should be stored inside the electrical switch-yards

### Maintenance:

Provision shall be made for routine inspection and maintenance of all ladders. Broken or damaged ladders shall be promptly repaired or removed and destroyed. Ladders ready for use should be tagged “Safe to use” on green background while unsuitable ladders should be tagged “Not for use” in red background.

**Safe to use**

**Not for Use**

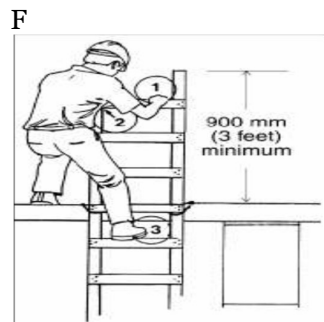
### Securing ladders:

All ladders shall be placed on firm ground, secured at top and intermediate positions ( in case length is more than **4 meters**) to maintain them rigidly in place and to support the loads imposed upon them. Ladder should be so rigid designed that it can withstand impact load of 8 KN in case of fall of a person using rope grab.

### Restrictions:

Ladders shall not be used as work platforms or as structural members of scaffolds or as walkways. **Ladders shall not be used in horizontal position.**

<b>CAUTION</b>	Do not carry anything in hand while climbing up or down on a ladder. Not more than one person will be allowed to ascend / descend at a time Always ensure three-point contact
----------------	---



**Figure illustrating three-point contact**

### Straight Ladders, Extension Ladders

- Rung spacing shall not be more than 300 mm and minimum width should be 400mm.
- Ladder rungs shall be preferably flat type to prevent slipping/rolling. All the ladders shall meet IS:3696 (Part-2)-2002 specification and be of industrial type Class-A.
- Landing platforms shall be provided at every 6 M on vertical ladders.

Corporate Standard Rules & Procedure Sub-Committee	Date	06-07-2014
	Standard Document No.	HZL/SRPSC/01
<b>Working at Height Standard</b>	Revision No.	02 (22.02.2023)
	Page No.	Page 18 of 33

- **Monkey ladder to cage strip clear distance shall not be less than 680 mm and not more than 760 mm.**
- **Cage guard will be provided from 2.1 M onwards. Provision of vertical lifeline with rope-grab/retractable lanyards needs to be evaluated in the absence of the cage.**
- Ladder shall extend minimum 1 M above stepping point. The topmost 3 rungs of the ladder shall not be used for working.
- **Snap chains/gate shall be provided at the end of landing platform and the ladder.**
  - When a straight ladder or extension ladder is being used for access to a work area (as opposed to working from the ladder) where frequent trips up the ladder will be made, consideration shall be given to providing fall protection such as a retractable lifeline or a vertical lifeline with rope grab for those climbing the ladder.
  - Ladder shall be placed as shown in figure below i.e the distance of the ladder bottom should not be more than  $\frac{1}{4}$  th of the working height (at least 75 deg angle to the floor). (refer photograph)

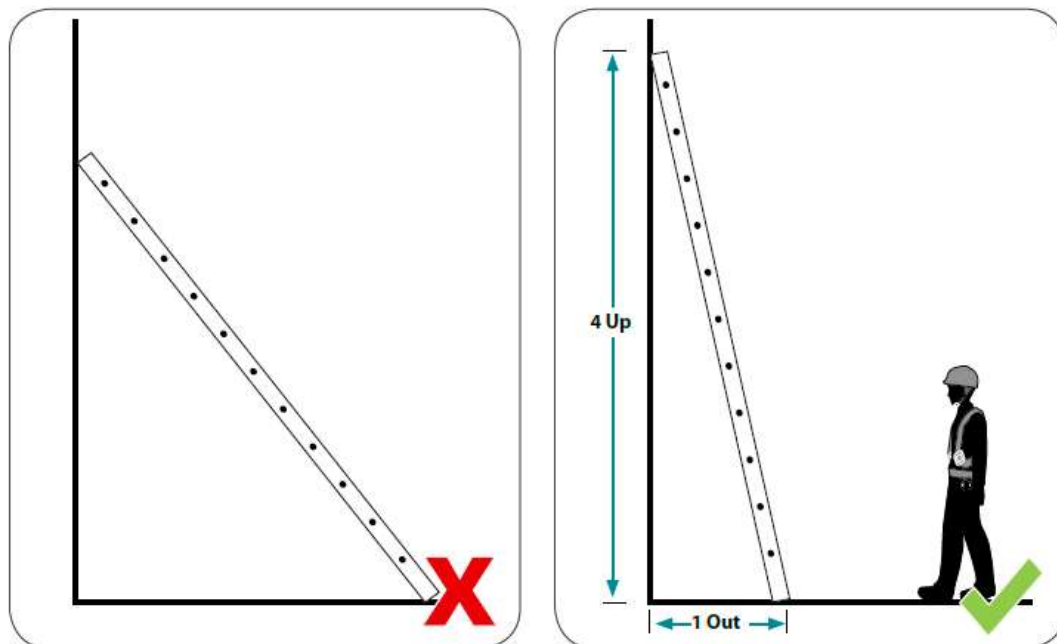


Figure 11.4: The ratio of the height to the base for a correctly positioned ladder is 4:1.

**Figure: The ratio of the height to the base for a correctly positioned ladder is 4:1**

### **Scaffolds**

Fall protection is required whenever working from scaffolds 1.8M or higher above the ground or floor level. For details refer **HZL Scaffold standard**.

Fall protection is required whenever working from scaffolds 1.8 meter or higher above the ground or floor level that have incomplete standard handrails or standard mid-rails or is not completely decked.

Corporate Standard Rules & Procedure Sub-Committee	Date	06-07-2014
	Standard Document No.	HZL/SRPSC/01
<b>Working at Height Standard</b>	Revision No.	02 (22.02.2023)
	Page No.	Page 19 of 33

Fall protection is required whenever working outside the plane of the handrails or if working against the handrails with awkward body position. Personnel shall not climb on, or work from, any scaffold handrail, midrail, or bracing member and shall use ladders to get into the scaffold.

On scaffolds of 12 feet or higher, fall protection shall be considered for those climbing the scaffold ladder (based on number of people on scaffold, number of climbs per day, etc). Consideration should be given to the amount of risk associated with installing the equipment versus the risk involved in climbing the ladder without fall protection.

Fall protection may be required when climbing scaffolds of less than 12 feet if there is an unusual hazard, such as a scaffold next to the edge of an elevated work area.

Fall protection shall be used while building scaffolds. Where practical, a retractable lifeline should be used to protect those building scaffolds but is not permitted to be attached to the scaffolding due to the side force thrust hazard. Double lanyards should be used in this case so that the person may maintain continuous anchorage.

If tying off to scaffolds, the stability of the scaffold must be considered. If the scaffold does not have adequate stability, it should be tied off to a permanent structure or fitted with outriggers to increase stability.

### **Self-retractable Lifelines**

Self-Retractable lifelines can be used as a method of providing vertical lifelines for ladders, scaffolds, etc. Self retracting lifelines and lanyards that automatically limit free fall distance to 610 mm or less shall be capable of sustaining a minimum tensile load of ~1360kg applied to the device with the lifeline or lanyard in the fully extended position.



### **6.1.4. Execution**

#### **Obtaining a Work permit for working at height:**

Working at height must be authorized through a Work permit for all activities and also for the activities listed below:

- a) Working at height over water.
- b) Working on Man basket/ boatswain's chair (only when no other alternative is available duly authorized accordingly to standards)
- c) Working on man lift/scissor lift near Overhead lines/barges

Corporate Standard Rules & Procedure Sub-Committee	Date	06-07-2014
	Standard Document No.	HZL/SRPSC/01
<b>Working at Height Standard</b>	Revision No.	02 (22.02.2023)
	Page No.	Page 20 of 33

- d) Working on Fragile roof/Side sheeting /Super structures
- e) Working on EOT/ Gantry Crane Maintenance
- f) It will also be required for special situations if deemed necessary by the Work Supervisor.

Corporate Standard Rules & Procedure Sub-Committee	Date	06-07-2014
	Standard Document No.	HZL/SRPSC/01
<b>Working at Height Standard</b>	Revision No.	02 (22.02.2023)
	Page No.	Page 21 of 33

### **Authorization and signatures**

Permit Initiator shall be responsible for raising the Work permit and shall do so only after verifying that the site is safe for work. Permit Issuer will release the permit after getting authorisation from Custodian. The Co-permittee (Work group member) shall accept the permit for execution of the work and comply with the permit requirement. Refer section 6.0 (General Requirement).

Prior to authorization, it must be verified that person(s) involved is free from abnormal health issues, height phobia or another illness which makes person unsuitable for working at height. The Work permit to be closed and returned to Permit Issuer (refer permit to work standard).

### **Duration**

Each permit shall identify the length of time for which it is valid. The permit shall not last longer than the duration of the job. However the permit has to be validated on shift basis.

(Details as per the permit to work standard of Hindustan Zinc Limited)

### **6.1.5 Inspection Requirements:**

- Each location will have a procedure for inspection of in-coming materials pertaining to work at height ( e.g. fall arresters, ladders, full body harness with double lanyards, OEM equipments, scaffold material etc)
- Inspection of full body harness with double lanyard:

<b>Type of Inspection</b>	<b>Periodicity</b>	<b>By</b>	<b>Remarks</b>
Self Inspection	Before every use	User	No record
Internal Inspection	Quarterly	S & FS	Record
External Inspection	Six monthly	Competent person	Record

- Inspections of fall arresting devices:

<b>Type of Inspection</b>	<b>Periodicity</b>	<b>By</b>	<b>Remarks</b>
Self Inspection	Before every use	Supervisor	No record
Internal Inspection	Quarterly	S & FS	Record
External Inspection	Yearly	OEM	Record

- Inspections of safety net:

<b>Type of Inspection</b>	<b>Periodicity</b>	<b>By</b>	<b>Remarks</b>
Self Inspection	Before installation and daily before starting the job	Supervisor	No record
Internal Inspection	Quarterly	S & FS	Record

- Inspections of Man basket:

<b>Type of Inspection</b>	<b>Periodicity</b>	<b>By</b>	<b>Remarks</b>
---------------------------	--------------------	-----------	----------------

Corporate Standard Rules & Procedure Sub-Committee	Date	06-07-2014
	Standard Document No.	HZL/SRPSC/01
<b>Working at Height Standard</b>	Revision No.	02 (22.02.2023)
	Page No.	Page 22 of 33

Internal Inspection	Before every use	Supervisor/ Foreman	Record PTW
External Inspection	Six monthly	Competent person	Record

- Man lift, scissor lift, Goods cum passenger lift, Single/Twin Mast working Platform (OEM):

Type of Inspection	Periodicity	By	Remarks
Internal Inspection	Before use	Operator	Daily checklist
External Inspection	Six monthly or OEM recommendation (whichever earlier)	Competent person	Record

- Inspection of ladders:

Type of Inspection	Periodicity	By	Remarks
Self Inspection	Before every use	User	No record
Internal Inspection	Quarterly	S & FS	Record

### 6.1.6. Training

All personnel who work at height must be initially given practical training on the use of fall protection devices. HZL should work with the suppliers/vendors of fall protection equipments to set up practical training sessions, including demonstration on the proper use and storage.

Each location must also identify members for a rescue team and ensure that appropriate practical training is provided to the rescue team members on a pre-determined frequency decided by the location.

### 6.1.7. Special requirements

#### Working at Height over water

In addition to fall protection, where potential to fall into water exists, all persons shall wear Personal Flotation Device (PFD). Life Saving Apparatus (like lifebuoy etc) shall be made available at location before the start of work. Ensure additional supervision during execution of the job.

#### Adverse Weather conditions

Permit Applicant will advice Permit Holder to suspend working at height under adverse weather conditions such as heavy rains, high winds, lightening fog , heat wave etc

#### Working at Height during night

Corporate Standard Rules & Procedure Sub-Committee	Date	06-07-2014
	Standard Document No.	HZL/SRPSC/01
<b>Working at Height Standard</b>	Revision No.	02 (22.02.2023)
	Page No.	Page 23 of 33

Generally all the work at height is to be planned during day time only. However for working at height during night, risk assessment should focus on proper illumination of the area, including access and back-up arrangement.

### **Radiography work at height**

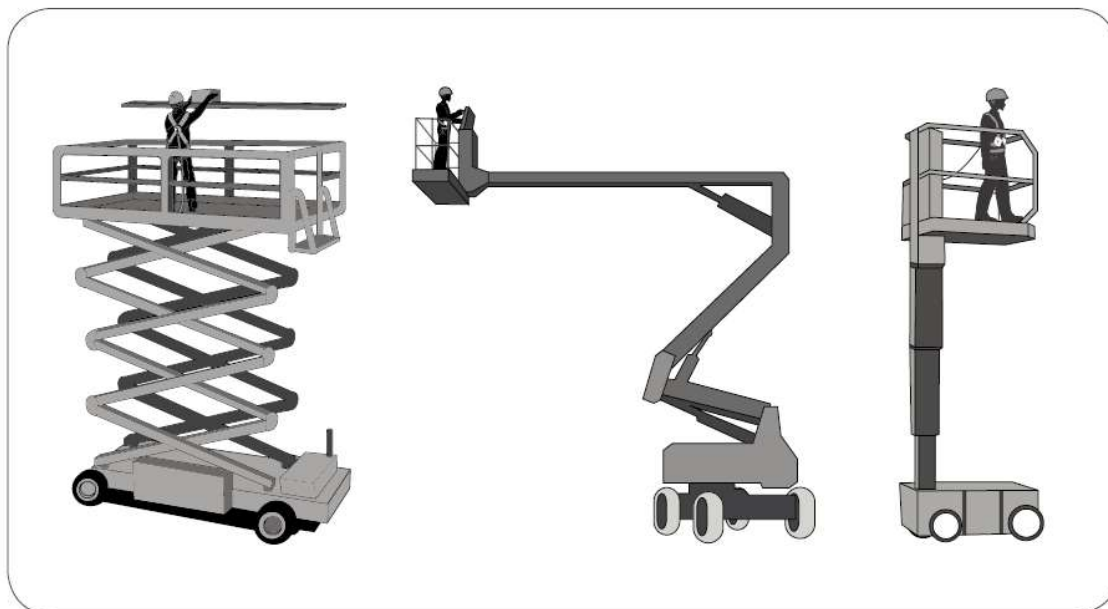
Proper communication should be ensured for protecting people working at height from radiation hazard. Adequate precaution shall be taken for ensuring that the radiography source is handled safely during shifting and kept securely when at height.

### **Man basket/ Man lift / Scissor lift etc operations**

When performing man lift operations, all personnel in the personnel basket (platform) must wear a full body harness with the double lanyard tied-off to an approved anchor point (refer photograph).

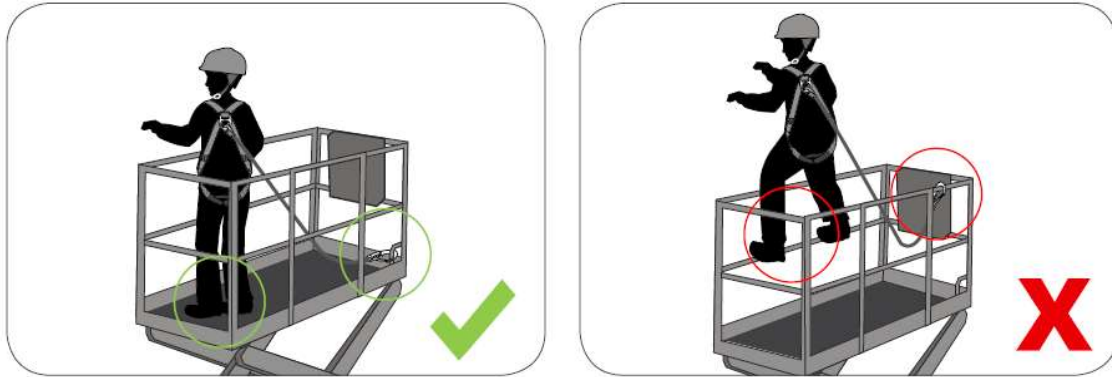
The anchorage points provided by the manufacturer of the equipment should be used. Use of these equipment on the barge will require risk assessment to be done.

When using Man basket, the crane, basket and associated tools/ tackles etc will be evaluated for suitability before use by the Area Supervisor. The crane, basket and tools/tackles used in the Man basket operations shall follow HZL laid down specifications that shall meet or exceed the local regulations, if any.



**Figure: Examples of Elevated Work Platforms, scissor lift (left) boom lift (middle) and vertical personnel platform (right)**

Corporate Standard Rules & Procedure Sub-Committee	Date	06-07-2014
	Standard Document No.	HZL/SRPSC/01
<b>Working at Height Standard</b>	Revision No.	02 (22.02.2023)
	Page No.	Page 24 of 33



**Figure: Correct method of working in an elevated work platform (left) and unsafe practices (right)**



Corporate Standard Rules & Procedure Sub-Committee	Date	06-07-2014
	Standard Document No.	HZL/SRPSC/01
<b>Working at Height Standard</b>	Revision No.	02 (22.02.2023)
	Page No.	Page 25 of 33

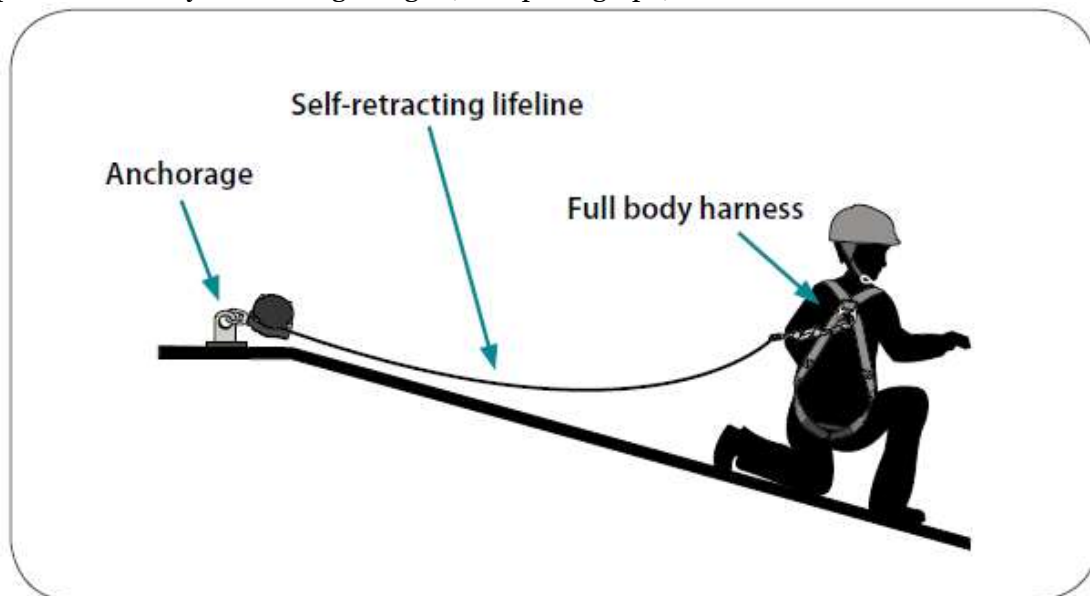
### **Fragile, Sloping roofs**

#### **Fragile roofs**

All sheeting roofs are considered to be fragile therefore three layer protection must be used in form of crawling ladders / boards fall arrest system and safety net while working in roof sheets and thus no separate protection is required in the already existing skylights . Also in case of any new installation skylights to be erected in the sides and not on the top of the roof to eliminate fall from skylights failure . li

#### **Sloping roofs**

Before working on a sloping roof ensure anchor points are available for fixing of lifeline, if not provided already at the design stage. (refer photograph)

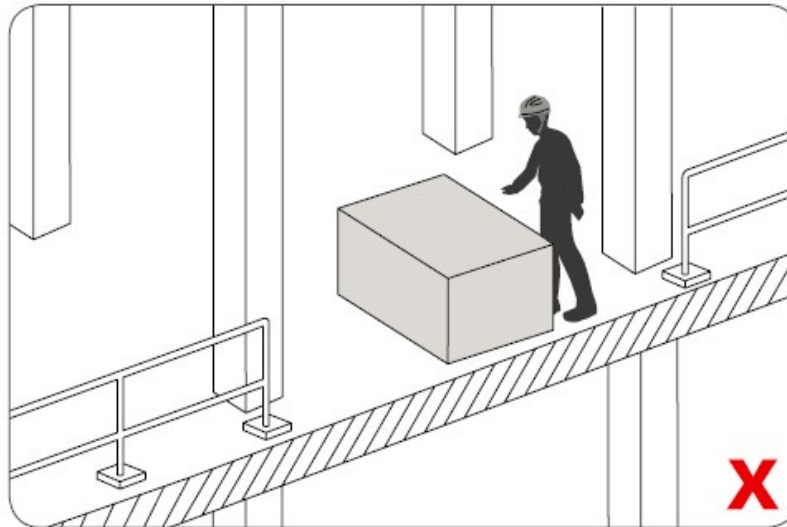


**Figure: An example of personal fall arrest system for roof works**

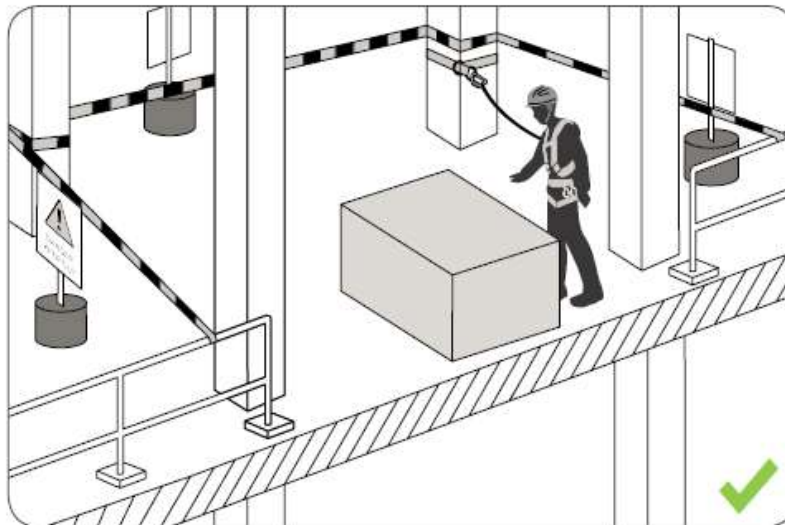
### **Structure erection/ working on structures**

- Fall protection is required whenever working in an elevated work area 1.8M higher above the floor, where handrails do not exist.
- Double lanyards should be used to provide continuous anchorage while moving along pipe racks, cable trays, etc.
- Lanyard length should be kept as short as practical to limit the potential fall distance. This is accomplished by utilizing an anchorage point overhead and not below the waistline
- When working on roofs, fall protection equipment shall be used when working less than 1.8M from roof edges, unless roof edges are protected by a Protective Barricade. Additionally, any work on a sloped roof requires fall protection.

Corporate Standard Rules & Procedure Sub-Committee	Date	06-07-2014
	Standard Document No.	HZL/SRPSC/01
<b>Working at Height Standard</b>	Revision No.	02 (22.02.2023)
	Page No.	Page 26 of 33

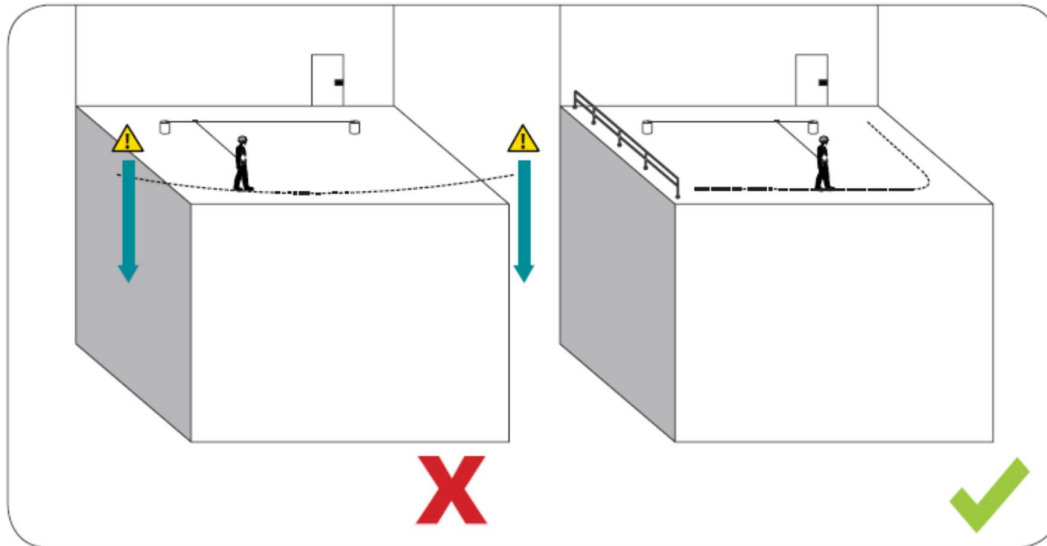


**Figure: Inadequate demarcation and worker protection during temporary removal of edge protection**



**Figure: Example of proper demarcation and travel restraint for worker during temporary removal of edge protection**

Corporate Standard Rules & Procedure Sub-Committee	Date	06-07-2014
	Standard Document No.	HZL/SRPSC/01
<b>Working at Height Standard</b>	Revision No.	02 (22.02.2023)
	Page No.	Page 27 of 33



**Figure: Example of incorrect use (left) and correct application (right) of a travel restraint system.**

### **Pipe racks and cable trays, tank roofs, lighting towers**

#### **Pipe racks and cable trays:**

While working in pipe racks, etc., if no overhead anchorage point is available, the lanyard should be tied off at foot level and all movement must be done by crawling. "Walking the pipes" is not permitted if no overhead anchorage point/ tie-off point exist. If "Walking the pipes" is utilized, the material of construction, diameter, wall thickness and integrity must be evaluated physically to assure pipes will support the load.

Cable tray shall not be used for taking anchor support for safety harness.

#### **Tank Roofs:**

All tank roofs shall be provided with independently supported walkways/ platform wherever there is requirement to work on it.

Permanent independent structures will be preferred in following cases:

- Where regular inspection/ work are required i.e. minimum once a month.
- Where corrosion chances are high due to nature of storage or work environment e.g. Acid, Caustic, other corrosive & chemical storage tanks.

Only in remote instances, when all above not possible, alternative means is to be used such as:

- The tank/vessel inspection and documentation is maintained & reviewed.
- Proper prior risk assessment of the work environment. The entry of the tank roof directly without a walkway / platform is required then the activity becomes a work @ height activity and all necessary requirement must be looked into and wearing of fall protection is mandatory requirement .
- Proper PPEs as specified for the job to be performed including full body harness and fall arrestors.
- Make sure tank/vessel must be capable of supporting the intended load (personnel, tools, etc.).

### **Pond and water body reservoirs**

Corporate Standard Rules & Procedure Sub-Committee	Date	06-07-2014
	Standard Document No.	HZL/SRPSC/01
<b>Working at Height Standard</b>	Revision No.	02 (22.02.2023)
	Page No.	Page 28 of 33

**All ponds and water body reservoirs must be barricaded from all sides with access control . Also the dept of the pond must be mentioned and the rope and lifebuoy must be available in all the arease where drowing is possible . Also whenever entry is made inside the barricaded area person must use fall restraint devices to prevent exposure to falling into and subsequent drowning .**

#### **Insulation and painting jobs at height:**

For work involving painting jobs on equipment, pipelines, structures, buildings, roofs and insulation jobs on equipment / pipelines requiring persons to work from elevations 1.8M or more from ground, proper scaffolds or portable elevated work platforms shall be provided and used, if there is no permanent provision is available to work safely. Ladders and other make shift devices shall not be used for painting and insulation jobs.

#### **Confined space at height**

While working in confined space at height use of rescue harness and self-retractable full body harness is a must. Refer Confined Space standard for details.

#### **Working at > 10 meters height**

An additional assistant will be provided for such jobs. Means of communication between additional assistant and people working at height shall be established before start of work. Work and rescue plan shall be prepared before start of work. Rescue plan is to be made as a part of JSA for work at height activities which may require rescue team. Permit Custodian should be minimum SBU /Dept Head.

#### **Inspection, Loading and unloading of materials**

Man lift / ladders would be used with Safety Harness for fall protection while working on height more than 1.8 M while inspection, loading/ unloading material from trailers/ dump trucks.

#### **Special hazards: Honeybees, birds etc**

In case of hazard of Honeybees, appropriate risk assessment needs to be done. Person who will work at height to remove the Honeybees must wear appropriate PPE (example PVC apron with hood, including full face mask).

Corporate Standard Rules & Procedure Sub-Committee	Date	06-07-2014
	Standard Document No.	HZL/SRPSC/01
<b>Working at Height Standard</b>	Revision No.	02 (22.02.2023)
	Page No.	Page 29 of 33

## 7.0 RACI chart

The roles and responsibilities to implement this standard are outlined below:

Activity Description	Area Supervisor/ Shift Incharge	Line Organization	S & FS	Zone Apex	CSC
Identification and assessment of site conditions	R	A	C	-	-
Planning, Preparation, Risk Assessment	R	A	C	-	-
Assign responsibility for implementing control measures	R	A	C	-	-
Protective and Rescue equipment plan	R	A	C	C	-
Ensure Job execution	R	A	C	-	-
Training and Certification	-	R / A	C	I	-
Audit/Inspection and monitoring for compliance	-	A	R/C	C/I	I
Identify Rescue Team	R	A	I	C	-

### **R : Responsible**

People who are expected to actively participate in the activity and contribute to the best of their abilities.

### **A : Accountable**

The person who is ultimately responsible for the results.

### **C : Consulted**

People who have the specific expertise and can contribute to decision making.

### **I : Informed**

People who are kept informed, but do not necessarily participate in the effort.

Corporate Standard Rules & Procedure Sub-Committee	Date	06-07-2014
	Standard Document No.	HZL/SRPSC/01
<b>Working at Height Standard</b>	Revision No.	02 (22.02.2023)
	Page No.	Page 30 of 33

## 8.0 Key Performance Indicators:

- Number of Work Permits issued
- Number of Risk Assessments (HIRA/ JSA) prepared
- Number of compliance audits conducted
- Audit results

## 9.0 Management Systems

### 9.1 Support Resources

Location head /Unit head / CSC/ Corporate EOHS/ S&FS is available to assist with implementation of this standard

### 9.2 Management Records

Site Work permits and audit checklists records shall be retained for two years or till the completion of the project, whichever is later.

Records to be maintained are as follows:

- Periodic Inspections of full body harness with double lanyard for 6 months.
- Periodic Inspections of fall arresting devices for 6 months.
- Periodic Inspections of safety net for 6 months.
- Periodic Inspections of Man basket, Man lift, scissor lift', Goods cum passenger lift, Single/Twin Mast working Platform for 3 years.
- Inspection records of various types of ladders for 6 months.
- Training of persons for working at height for two years

### 9.3 Audit Requirements

Each location shall audit compliance with this standard as part of its Safety audit program.

### 9.4 Standard Renewal Process

This standard shall be reviewed and revised as necessary and, at a minimum, not later than three years from the date of the last revision.

### 9.5 Deviation Process

Deviations from this standard must be authorized by the CSC after consultation with the APEX. Deviations must be documented, and documentation must indicate causes of deviation with safety plan. Deviation authorization must be renewed periodically and at no less frequently than every three years.

### 9.6 Training and Communication Requirements

Each Zone or location must be familiar with this standard to carry out its responsibilities. Training is the responsibility of each Zone / location.

### 9.7 Contact

In the event that interpretation or clarification is needed, questions shall be directed to the Safety & Fire Services Head and Zone/ Corporate SRP sub- committee.

Corporate Standard Rules & Procedure Sub-Committee	Date	06-07-2014
	Standard Document No.	HZL/SRPSC/01
<b>Working at Height Standard</b>	Revision No.	02 (22.02.2023)
	Page No.	Page 31 of 33

### 10. Fall Arrest System Checklist

S. No.	Question	Y/N
	<b>Anchorage Points</b>	
1	Do workers know appropriate anchorage points for each task that requires a fall-arrest or restraint system?	
2	Are all anchorage points capable of supporting at least 5,000 pounds (2,268 kilograms)	
3	per person attached? OR is the complete fall-arrest system rated at a safety factor of at least two and supervised by a qualified person?	
4	Are all anchorage points for body harnesses located at shoulder height and are anchorage points for self retracting lifeline systems located overhead?	
5	Are anchorage points independent of the working surface?	
6	Can a worker move from one station to another or climb up and down without exposure to a fall?	
7	If the lifeline, lanyard, or self-retracting lifeline is not permanently attached to an anchorage point at the elevated work area, is the first worker up or the last worker down protected while climbing and traversing?	
	<b>Vertical Lifelines</b>	
1	Does the lifeline have a minimum breaking strength of 5,000 pounds (2,268 kilograms)?	
2	Is the lifeline protected from abrasive or cutting edges?	
3	Does the system provide fall protection as the worker connects to and releases from the lifeline?	
4	Is the lifeline arranged so workers never have to hold it for balance? (A lifeline should never be used for balance.	
5	Is the vertical segment integrated with the horizontal segment to provide continuous fall protection?	
	<b>Horizontal Lifelines</b>	
1	Has the entire horizontal lifeline system been designed and approved by a qualified person?	
2	Have the anchorages to which the lifeline is attached been designed and evaluated specifically for a horizontal lifeline?	
3	Has the designer of the system approved the number of workers who will be using it?	
4	Is the rope or cable free from signs of wear or abrasion?	
5	Does the rope or cable have the required initial sag?	
6	Have the workers been warned about potential falls?	
7	Have the clearances been checked?	
8	Is the hardware riding on the horizontal lifeline made of steel? (Aluminum is not permitted because it wears excessively.)	
	<b>Fall Arresters (Rope Grabs)</b>	

Corporate Standard Rules & Procedure Sub-Committee	Date	06-07-2014
	Standard Document No.	HZL/SRPSC/01
<b>Working at Height Standard</b>	Revision No.	02 (22.02.2023)
	Page No.	Page 32 of 33

1	Is the fall arrester compatible with the lifeline on which it is to be installed or operated?	
2	Is the fall arrester in operational condition?	
3	Is the fall arrester equipped with a changeover lever that allows it to become a stationary anchor on the lifeline?	
4	Is the fall arrester equipped with a locking mechanism that prevents unintentional opening of the device and subsequent disengagement from the lifeline?	
5	Is the fall arrester's "up" direction marked properly so the equipment can be attached to the line correctly?	
6	Is the fall arrester included in a regular maintenance program?	
	<b>Lanyards</b>	
1	Is the lanyard length as short as necessary and in no cases greater than 6 feet (1.8 meters)?	
2	Are manually adjustable lanyards used when it is desirable to be able to take slack out of the lanyard?	
3	Does the lanyard have a shock-absorbing feature to limit the arresting forces to 500-600 pounds (227-272 kilograms)?	
4	If the lanyard has a shock absorber, is it obvious to the user that the shock absorber has been deployed?(Is there a warning label, broken pouch, etc.?)	
5	Have you prohibited tying of knots from the lanyard to the lifeline? (Mechanical grabs or fall arresters must be used.)	
6	Are double lanyards provided ?	
	<b>Retractable Lifeline (RL)</b>	
1	Are workers properly trained to use an RL?	
2	Is the RL under a regular maintenance and inspection program?	
3	Is the end of the cable properly spliced? (thimble eye, Flemish eye-spliced, and swaged fitting/ferrule?)	
	<b>Snap Hooks</b>	
1	Have double-locking snap hooks been used?	
2	Is the snap hook attached to the D-ring, eyebolt, or other hardware in a manner approved by the manufacturer of the snap hook?	
3	Are snap hooks inspected regularly for stress, wear, distortion, and spring failure?	
4	Are snap hooks arranged so they are never connected to each other? (They should NOT be connected to each other.)	



Corporate Standard Rules & Procedure Sub-Committee	Date	06-07-2014
	Standard Document No.	HZL/SRPSC/01
<b>Working at Height Standard</b>	Revision No.	02 (22.02.2023)
	Page No.	Page 33 of 33

<b>Body Harnesses</b>		
<b>1</b>	Are full-body harnesses selected for a particular job equipped with all necessary attachment points (for fall arresting, work positioning, descent control, rescue, or ladder fall-protection systems)?	
<b>2</b>	Are body harnesses inspected regularly for wear, abrasion, broken stitching, and missing hardware?	
<b>3</b>	Is the Velcro® type of closure prohibited from all load-bearing connections?	
<b>4</b>	Have workers been instructed in the use and care of body harnesses/body belts?	
<b>Other Considerations</b>		
<b>1</b>	Has the free-fall distance been considered so that a worker will not strike a lower surface or object before the fall is arrested?	
<b>2</b>	Have pendulum-swing fall hazards been eliminated?	
<b>3</b>	Have safe methods to retrieve fallen workers been planned?	
<b>4</b>	Is all of the fall-arrest equipment free of potential damage from welding, chemical corrosion, or sandblasts?	
<b>5</b>	Are all components of the system compatible according to the manufacturer's instructions?	
<b>6</b>	Have employees been properly trained in the following issues? – Manufacturer's recommendations, restrictions, instructions, and warnings – Location of appropriate anchorage points and attachment techniques – Problems associated with elongation, deceleration distance, method of use, inspection, and storage	
<b>7</b>	Are all regular inspections performed by trained inspectors?	
<b>8</b>	Are written reports maintained?	